

KISII UNIVERSITY
UNIVERSITY EXAMINATIONS

SPECIAL/SUPPLEMENTARY EXAMINATIONS
FIRST YEAR EXAMINATION FOR THE AWARD OF THE DEGREE OF
BACHELOR OF SCIENCE IN MEDICAL LABORATORY SCIENCES
SECOND SEMESTER, 2024/2025
(AUGUST, 2025)

MELS 123: PHYSICS FOR MEDICAL LABORATORY SCIENCES

STREAM: Y1S2

TIME: 2 HOURS

DAY: WEDNESDAY, 9:00-11:00 AM

DATE: 13/08/2025

INSTRUCTIONS

- 1. Do not write anything on this question paper.**
- 2. Answer question ONE (compulsory) and any other TWO questions.**

- **Make use of the following constants;**
 - **Molar mass of nitrogen= 28kg/Kmol**
 - **Universal gas constant $R_0=8314.3 \text{ Nm/Kmol}$**
 - **Specific latent heat of fusion of ice = 333 000 J kg-1**
 - **Specific latent heat of vaporization of steam = 2260000 J kg-1**
 - **Specific heat capacity of steam = 2010 Jkg-1 k-1**
 - **Specific heat capacity of water = 4 200 Jkg⁻¹ k⁻¹**
 - **Specific heat capacity of ice = 2 090 Jkg⁻¹ k⁻¹**
 - **Planks constant $h,=6.64 \times 10^{-34} \text{ Js}$**
 - **$1/4\pi\epsilon_0 = 9 \times 10^9 \text{ xFm}^{-1}$**

QUESTION ONE (COMPULSORY – 30 MARKS)

(a) What is a vector quantity? Give any **two** examples of vector quantities.

(2 marks)

(b) Calculate the force between two charges of 10^{-5} C separated by a distance of 0.2 m in a vacuum.

(3 marks)

(c) Calculate the refractive index for a ray of light moving from water to diamond given that the speed of light in water = $2.26 \times 10^8 \text{ ms}^{-1}$ and Speed of

light in diamond = $1.25 \times 10^8 \text{ ms}^{-1}$.
(2 marks)

(d) State any two properties of X-rays (2 marks)

(e) If 600g of argon have a pressure of $1.5 \times 10^5 \text{ Pa}$ and a volume of 0.3 m^3 what is the temperature of the gas? (**Molar mass of argon = 40g**)
(3 marks)

(f) Describe any **three** uses of radioisotopes (2 marks)

(g) A concave mirror of focal length 9 cm forms an image of a real object 3 cm high placed 15 cm in front of it. Find;

- (i) the position
- (ii) nature and
- (iii) the size of the image. (4 marks)

(h) (i) Describe any **two** applications of electrostatics (2 marks)
(ii) Describe any **two** uses of capacitors (2 marks)

(i) If 200 J of work are done in compressing the air and 150 J of heat are conducted away through the walls of the cylinder what is the increase in the internal energy of the air. (3 marks)

(j) A couple of moment 7.5 Nm is applied for 5s to a disc of moment of inertia 0.15 kgm^2 . Calculate the change in angular velocity (ω) produced. (3 marks)

(k) Radium undergoes radioactive decay by emitting an alpha particle to form a daughter nuclide Q as in the reaction.

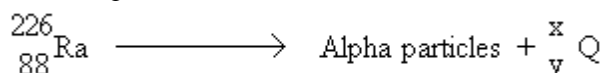

Determine the values of

- (i) x (1 mark)
- (ii) y (1 mark)

QUESTION TWO (20 MARKS)

(a) Give any two characteristics of an ideal gas (2 marks)

(b) A vessel of volume 0.2 m^3 contains nitrogen at 1.013 bar and 15° C . if 0.2 kg of nitrogen is now pumped into the vessel, calculate the new pressure when the vessel has returned to its initial temperature. (assume N_2 is a perfect gas) (6 marks)

(c) Using suitable P-V diagrams differentiate between an isothermal and an isochoric process.

(4 marks)

(d) A bucket of bricks of mass 120 kg is tied to one end of a rope which passes over a frictionless pulley so that it hangs vertically downwards. A man of mass 80 kg hangs onto the other end of the rope (See Figure 1).

Calculate:

(i) the tension in the rope holding the man (2 marks)

(ii) the tension in the rope holding the bucket (2 marks)

(iii) the acceleration of the man (2 marks)

(iv) the acceleration of the bucket of bricks (2 marks)

(v) the tensions in the two sections of the rope if it is held stationary on the pulley. (2 marks)

(Taking $g = 10 \text{ ms}^{-2}$)

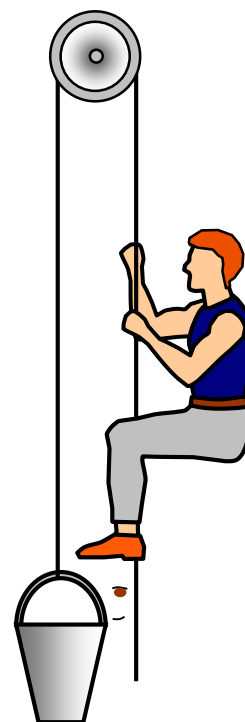

Figure 1

QUESTION THREE (20 MARKS)

Question THREE (20 MARKS)

Define the following terms

a) Angular acceleration (1 mark)

b) Angular displacement (1 mark)

c) A body has an angular velocity of 125 rad/s. Find the time it will take to make 550 complete revolutions. (3 marks)

d) A body attached to one end of a string 0.8m long is whirled in space in a horizontal circle at 30 revolutions per minute. What is the speed of the body along the circumference? (3 marks)

e) A model car moves round a circuit track of radius 0.4m at 2 revolutions per second.

What is:

i) Period T? (2 marks)

ii) Angular velocity ω ? (2 marks)

iii) Speed v? (2 marks)

f) The diagram below figure 4 contains suspension in a liquid. The tube is rotated in an horizontal circle as shown below.

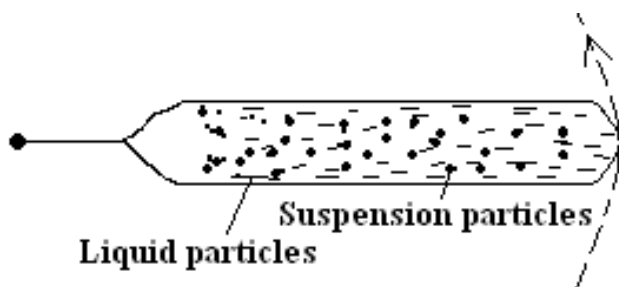

Figure 4

Explain what happens to the liquid and suspension particles. (2 marks)

g) The freezing point of peanut oil varies, but is approximately 3°C . Its specific heat capacities above and below freezing are 2.40 and $2.65 \text{ kJkg}^{-1}\text{K}^{-1}$, respectively, and its latent heat of fusion is 60kJkg^{-1} . How long would it take for the 1000 W hairdryer to change 1 kg of the oil from a solid at 233 K to a liquid at 40°C ? (4 marks)

QUESTION FOUR (20 MARKS)

(a) Some houses are heated by “night storage heaters” which use cheap electricity between the hours of midnight and 7.00am. Figure 4 shows a circuit diagram of three identical 230V , 3.5kW storage heaters connected to a 230V mains power supply of negligible internal resistance.

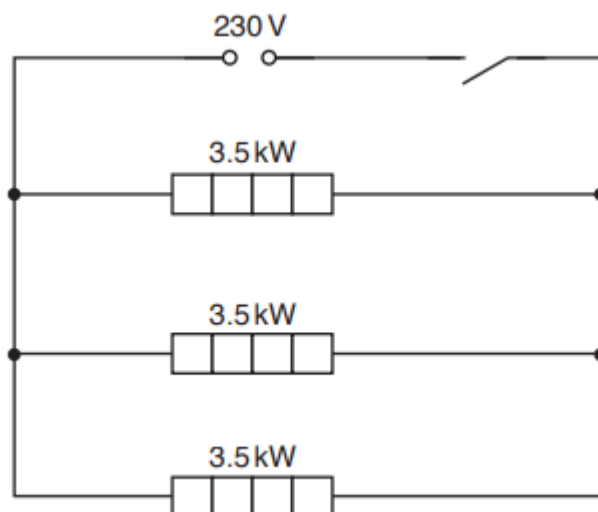

Figure 4

- (i) Show that the resistance of each heating element is about 15Ω when the heater is operating at 230V . (3 marks)
- (ii) The heating element is constructed from a metallic wire of resistivity $1.6 \times 10^{-6}\Omega\text{m}$. The radius of the wire is 0.55mm . Determine the length l of the metallic wire in one heating element. (3 marks)

(iii) The cost of 1kWh of energy is KSh.16.00. Calculate the cost of using the three storage heaters between midnight and 7.00am every night for one week.
(3 marks)

(b) A student monitors the temperature in a room by using a potential divider circuit containing a negative temperature coefficient (NTC) thermistor. The student sets up the circuit shown in Figure 5.

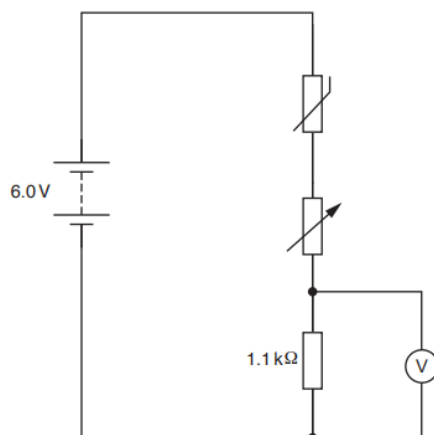

Figure 5

The battery has an e.m.f. of 6.0V and negligible internal resistance.

(i) When the temperature of the thermistor is 12°C the thermistor has a resistance of 6.8kΩ. The resistance of the variable resistor is set to a value of 1.4kΩ. Calculate the reading V on the voltmeter.
(3 marks)

(ii) Explain how the reading on the voltmeter will change when the temperature of the thermistor increases.
(3 marks)

(d) Describe the working principle of a Geiger-Muller tube.
(5 marks)

QUESTION FIVE (20 MARKS)

(a) This question is about a laser pen.

(i) Define the terms phase difference and coherence.
(2 marks)

(ii) Green light from the laser pen passes through a pair of narrow slits S₁ and S₂ as shown in Fig. 6.1.

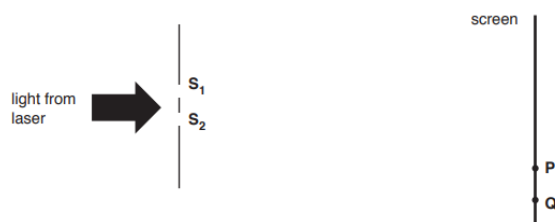

Figure 6.1

as A pattern is produced on a screen consisting of regularly spaced bright and dark lines shown in Fig. 6.2.

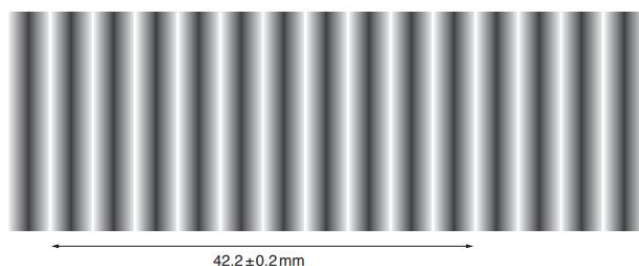

Figure 6.2

Fig. 6.1 shows two points, P and Q, on the screen. Explain in terms of path difference why point P is a bright line and point Q is a dark line. The screen is at a distance of $4.50 \pm 0.02\text{m}$ from the slits and the slit separation is $0.56 \pm 0.02\text{mm}$.

- (i) Use Fig. 6.2 to determine the wavelength λ of the light. (3 marks)
 - (ii) Determine the percentage uncertainty in λ . (3 marks)
 - (iii) The power of the green light from the laser pen is 50.0mW . It is now used in a demonstration of the photoelectric effect.
 - (1) Calculate the number of photons n that the laser emits per second. (3 marks)
 - (2) The green light falls on a negatively charged metal plate with a work function of 2.6eV . Explain whether photoelectrons will be emitted. (3 marks)
- (b) Two $250\ \mu\text{F}$ capacitors are joined in series to a 10V supply. Calculate:
- (i) the potential difference across each capacitor (3 marks)
 - (ii) the charge on each plate of each capacitor (3 marks)

